

Flexible jacket heaters with 20-125°C adjustable electronic thermostat, surface mounted, for metal containers

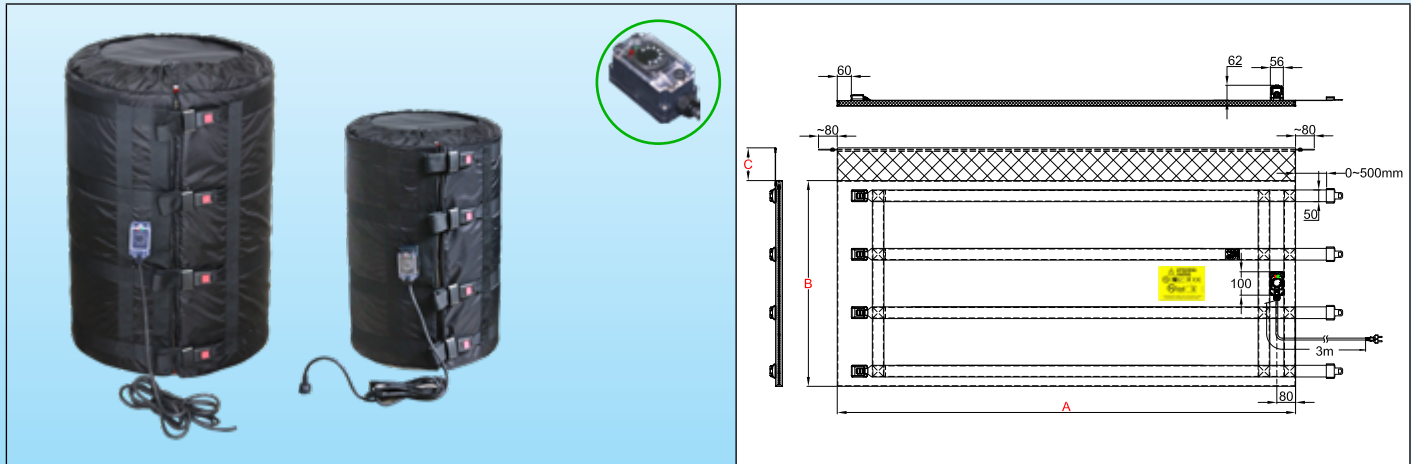

Because of permanent improvement of our products, drawings, descriptions, features used on these data sheets are for guidance only and can be modified without prior advice

Containers material	Maximum temperature limited to :	Tightening	Thermostat	Insulation thickness	Type
Metal	135°C	Nylon straps and metal buckle	Electronic, set point adjustable by knob from 20 to 125°C	20mm	9VJAE



Main Features

Thanks to its electronic thermostat, knob adjustable from 20 to 125°C, these flexible jacket heaters are used for antifreeze protection, reheating, temperature stabilization, to reduce viscosity or to melt soaps, animal or vegetable fats, varnishes, oils, food or chemical products.

This series of jacket heaters is the most **universal** solution, with economical electronic thermostat for **heating at a set temperature** glass or plastic containers. They are available for containers of 110L (30 US gallons) and 210L (55US gallons). The jacket heater covers the entire surface and is surmounted by a soft collar "a scarf" preventing it from sliding down. They are made **with three power levels**: (0.05W/cm² for temperature up to 50°C, 0.1W/cm² for temperature up to 80°C, and 0.135W/cm² for temperature up to 110°C). Their thickness of insulation is 20mm. In these models the surface temperature is limited to 135°C. When they are used with an insulated lid and an insulated pedestal, their energetic efficiency can rise 90%

Technical characteristics

The heating element of the flexible jacket heater consists of a network of silicone insulated heating wires shielded by a metal braid, taken under a cover sewn in PU and Teflon coated polyester fabric. A 20mm thick, temperature-resistant NBR-PVC foam insulation is inserted between the heating network and the outer wall. This insulating foam has an insulation coefficient (Lambda λ) of 0.039W/m.K, and this makes it possible to divide the energy losses by 3 compared to jacket heaters insulated with mineral wool or carbon fiber felt of the same thickness. Adjustable **metal** buckles allow quick assembly and disassembly and efficient clamping on the container. Their mechanical strength is exceptional.

Fabric covering:

- Internal heating face: Teflon coated polyester fabric,
- External side: waterproof PU coated polyester fabric.

Thermal insulation:

NBR-PVC foam, with closed cells and high temperature resistance, thickness 20mm.

Heating element:

Silicon insulated heating wire with metal braid providing mechanical protection against puncturing and good grounding.

Temperature control:

By an electronic thermostat adjustable from 20 to 125°C, located in a **waterproof** box mounted on the **external surface of the jacket heater**. It controls the temperature by means of a thermistor probe placed on the inner surface of the fabric in contact with the container. This probe has an anticipation loop avoiding overheating. A temperature limiter is incorporated in the heating net to limit the surface temperature to 135°C.

Connection cable:

Insulated rubber power supply cable, for industrial environments, 3 x 1mm² or 3x1.5mm² (depending of power), length 3m, Euro plug. UL plug on request.

Mounting on containers:

These jacket heaters feature nylon straps with quick-release adjustable buckles for adjustment to the diameter of the

Flexible jacket heaters with 20-125°C adjustable electronic thermostat, surface mounted, for metal containers



container, and a soft fabric collar without thermal insulation named scarf. This flexible scarf can be used to hold in place an insulating lid in the case of cylindrical containers.

Options:

- Electronic thermostat temperature range -40+40°C, 4-40°C, 30-90°C, 30-110°C
- Power supply 110/115V
- Power cord with industrial plug 2-pole + earth 16A CEE (IEC60309)
- Lids and insulating pedestals: see the accessories pages.

Compliance with standards: CE compliant. TUV certificate for EEC Low Voltage Directive (LVD) and EMC directive 2004/108/EC, and CE marked accordingly.

Main references (see the technical introduction for the liquids heating time)

References*	Volume, US gallons	Volume, Liters	Dia. (mm ± 12; Inch ± 1/2")	Height A (mm/inch)	Flat length B (mm/inch)	Scarf C (mm/inch)	w/cm ² (W/in ²)**	Max temp. °C	Watt	Voltage V
9VJAE731558550HG	30	110	460 (18.1)	730 (28.8)	1550 (61)	100 (3.9)	0,05 (0.32)	50	550	220/240
9VJAE881898880HG	55	210	585 (23)	880 (34.6)	1890 (74.4)	100 (3.9)	0,05 (0.32)	50	880	220/240
9VJAE731558A10HG	30	110	460 (18.1)	880 (34.6)	1550 (61)	100 (3.9)	0,1 (0.64)	80	1100	220/240
9VJAE881898A665G	55	210	460 (18.1)	1000 (39.4)	1890 (74.4)	100 (3.9)	0,1 (0.64)	80	1660	220/240
9VJAE731558A155G	30	110	460 (18.1)	880 (34.6)	1550 (61)	100 (3.9)	0,135 (0.86)	110	1500	220/240
9VJAE881898B255G	55	210	460 (18.1)	1000 (39.4)	1890 (74.4)	100 (3.9)	0,135 (0.86)	110	2250	220/240

* For these products supplied with UL plug and not Euro plug, replace the 15th character by X.

Because of permanent improvement of our products, drawings, descriptions, features used on these data sheets are for guidance only and can be modified without prior advice